

# AMD NEXT GENERATION 7NM RYZEN™ 4000 APU “RENOIR”

SONU ARORA, DAN BOUVIER, CHRIS WEAVER

Presented By:

SONU ARORA  
AMD FELLOW



# RYZEN 4000 SERIES APU

WORLD'S FIRST 8 CORE X86 PROCESSOR FOR ULTRATHIN NOTEBOOKS



**ANNOUNCED IN JAN 2020**



## HIGH PERFORMANCE

"Zen2" - with 15% higher IPC



## 7NM "VEGA" GRAPHICS

59% higher perf per CU

7nm

## 7NM TECHNOLOGY

2x Transistor Density



## POWER EFFICIENT

2x Performance/Watt

SEE ENDNOTES EPYC-09, RM3-250, RM3-01, RM3-123, RM3-130

# “RENOIR” APU GENERATIONAL PERFORMANCE

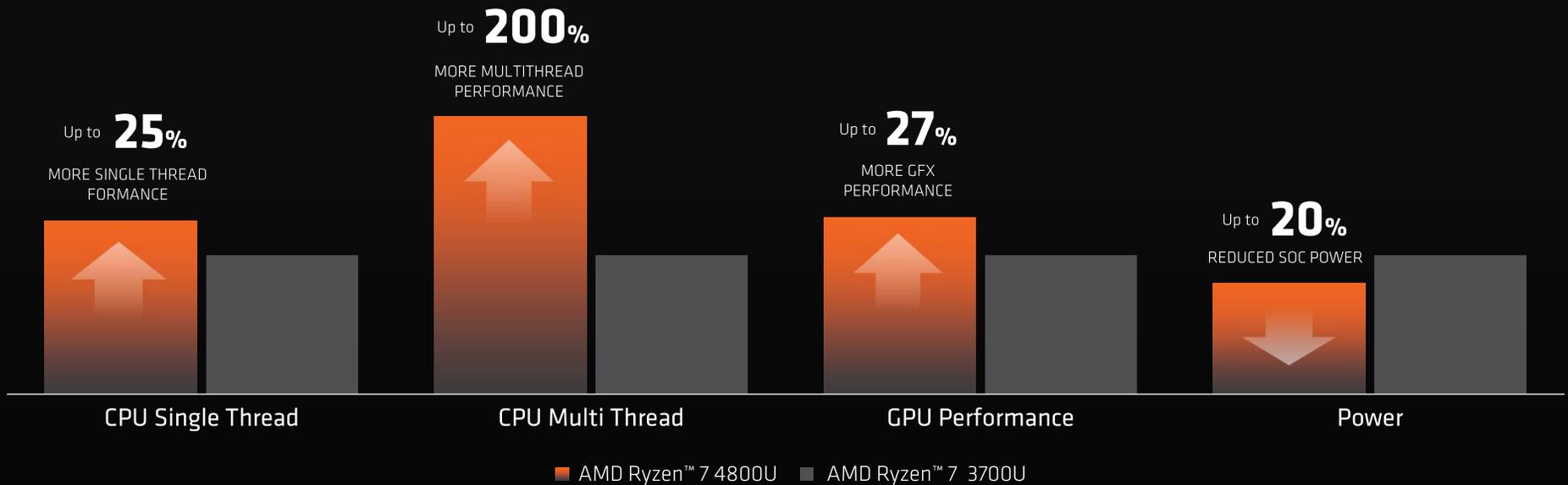

Delivered 8 high performance Cores in mobile form-factor

Scaled Graphics performance density by 3.25x. Per CU performance by 59%

Improved memory bandwidth efficiency

Upgraded audio-visual experience

Increased package performance density

SEE ENDNOTES RM3-06, RM3-123, RM3-250, RM3-129

# “RENOIR” APU

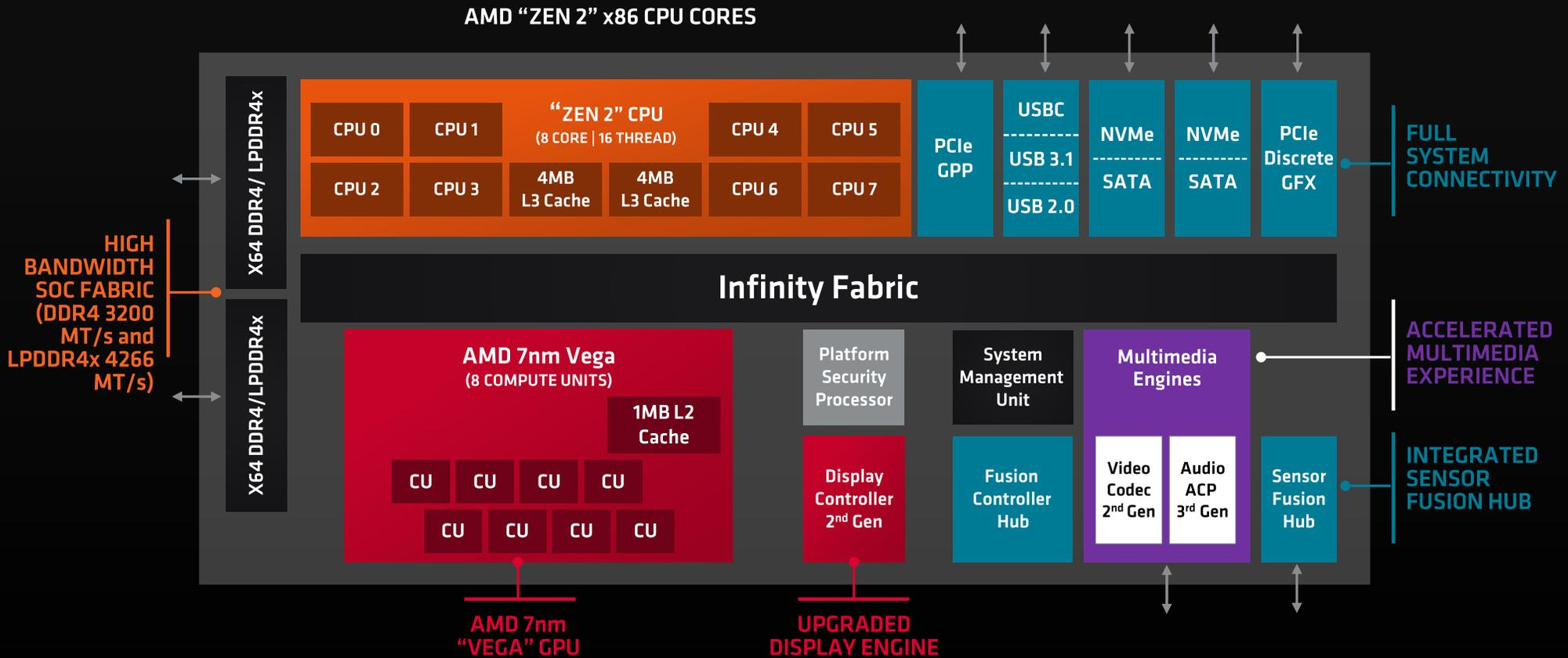

# SIGNIFICANT DENSITY INCREASE

## 7nm "RENOIR" Die

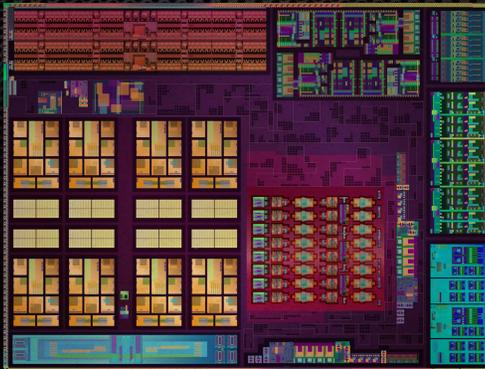

**Technology**  
**Transistor count**  
**Die Size**

TSMC 7nm – 13-layer metal  
9.8B  
156mm<sup>2</sup>

## In BGA and uPGA Package

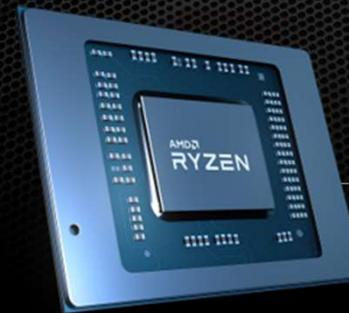

BGA: 25 x 35 x 1.38mm

**nearly 2x** transistors | **25%** smaller die  
**vs previous "Picasso" APU**

SEE ENDNOTES RN-1

# “ZEN 2” OPTIMIZED FOR APU

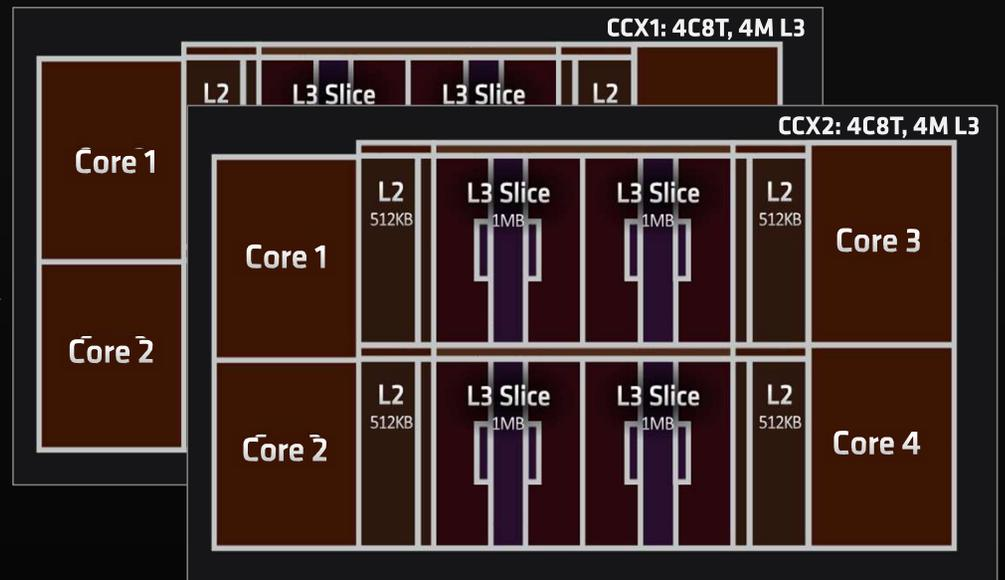
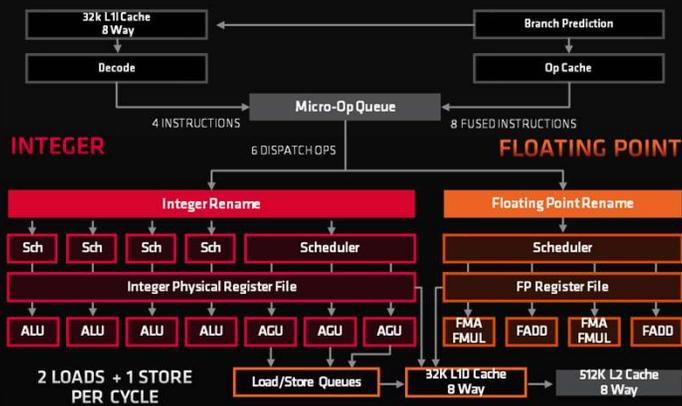

**15% IPC IMPROVEMENT  
FROM “ZEN” TO “ZEN 2”**

**CACHE HIERARCHY  
OPTIMIZED**

**TWO CORE COMPLEXES IN  
A MONOLITHIC APU DIE**

SEE ENDNOTES EPYC-09

# BALANCING POWER AND PERFORMANCE

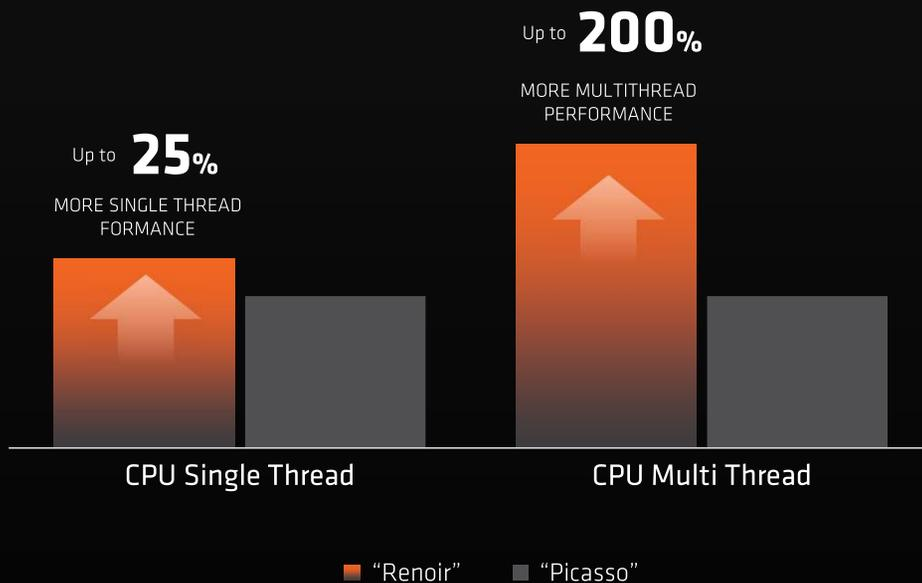

## SINGLE THREAD

- +15% IPC
- +10% Fmax

## MULTI THREAD

- +30% IPC and design
  - Improved branch prediction accuracy
  - Higher op cache hit rate
  - New integer scheduler algorithms
  - Clock and data gating improvements
  - Low-power design methodology
- +70% 7nm Density and Power Efficiency

**IN THE SAME 15W POWER AND THERMAL ENVELOPE**

SEE ENDNOTES RM3-06, RM3-123

# LEADERSHIP CPU PERFORMANCE

## LOW POWER NOTEBOOKS

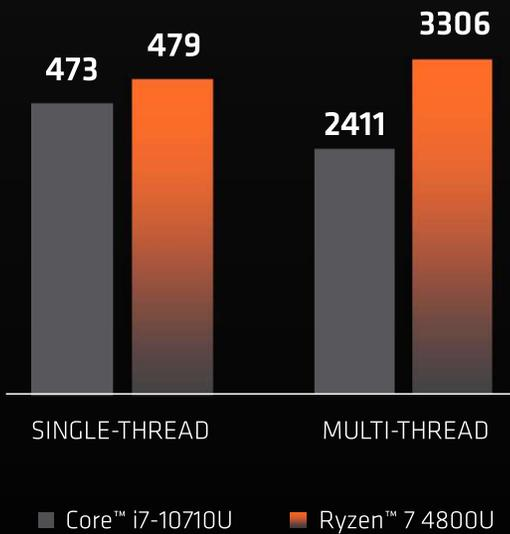

## ELITE GAMING NOTEBOOKS

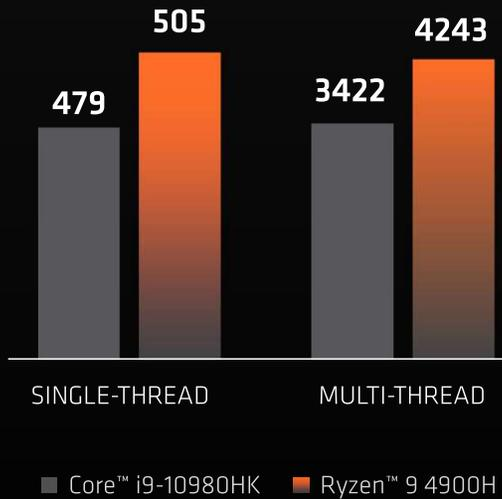

## DESKTOP

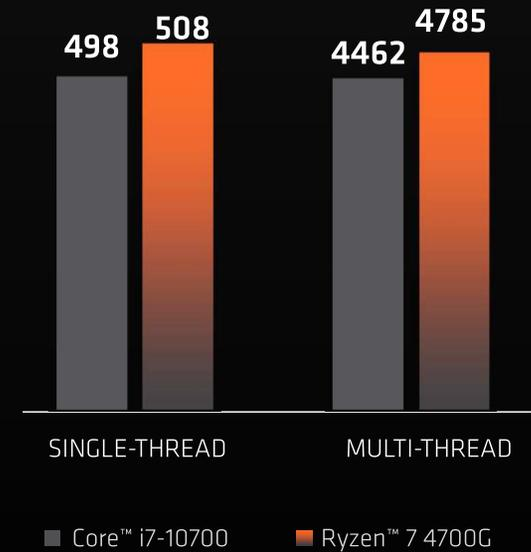

Cinebench R20

SEE ENDNOTES RM3-216, RM3-217, RZG2-68

# AMD RYZEN™ **9** 4900HS PROCESSORS

REDEFINING GAMING NOTEBOOK FORM FACTORS

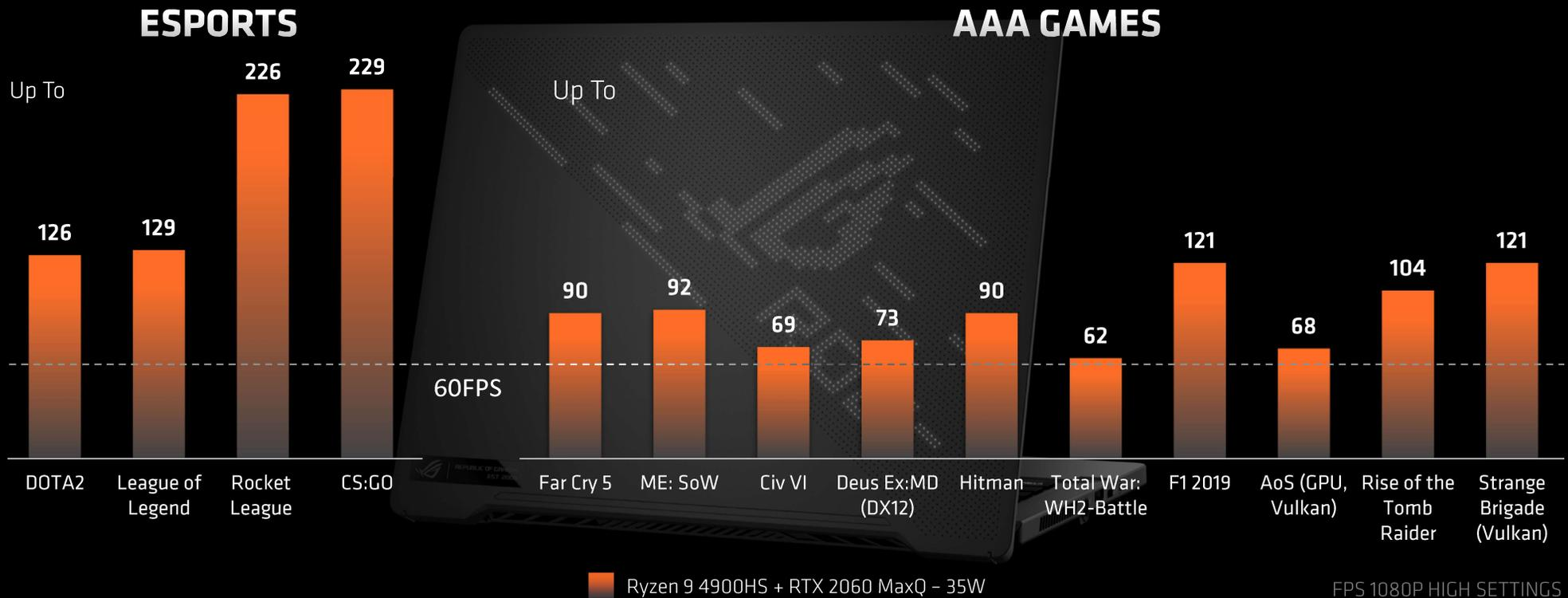

SEE ENDNOTES RM3H-21. RESULTS MAY VARY.



# 7NM "VEGA"

## MAXIMIZING EFFICIENCY PER COMPUTE UNIT

### REDUCED ENGINE SIZE FOR BETTER EFFICIENCY & HIGHER PERFORMANCE

- 2x wide Data Fabric interface for power efficient data transfer
- Graphics low power state transition optimization
- 25% higher peak graphics clock
- 77% higher peak memory bandwidth

### DELIVERED RESULTS

- Up to 59% higher Time Spy performance per Compute Unit
- 1.79 TFLOPS (FP32) peak throughput
- Same 15W power envelope as previous generation

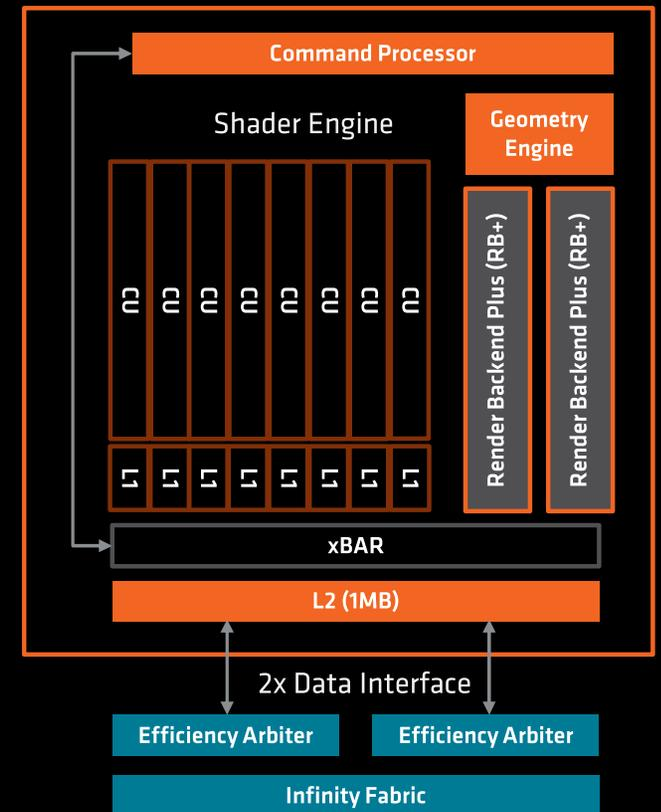

SEE ENDNOTES RM3-250.

# BREAKTHROUGH AREA EFFICIENCY

7NM "VEGA" GRAPHICS DELIVERS UP TO 225% MORE PERF/MM<sup>2</sup>

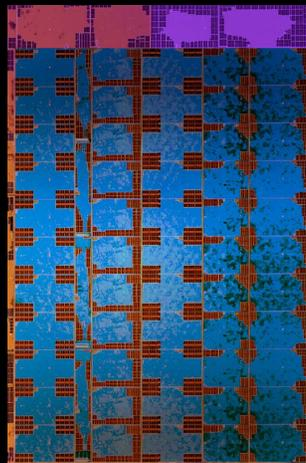

14nm "Vega"  
11CU

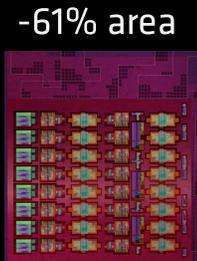

-61% area

7nm "Vega"  
8CU

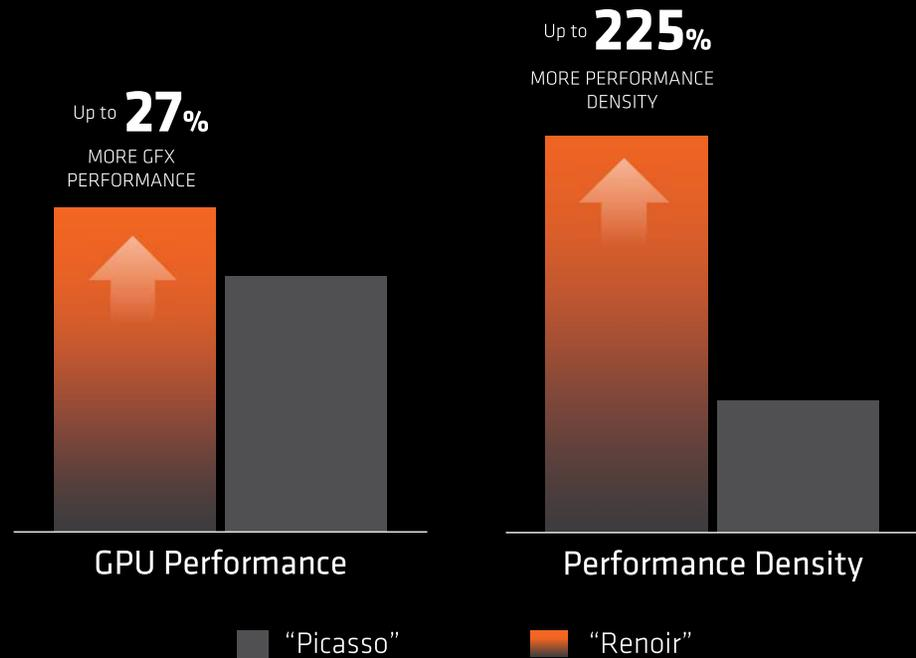

**1.75X FREQUENCY + 2.2X BANDWIDTH/CU + 7NM DENSITY**

SEE ENDNOTES RM3-250, RN-2

# MEMORY SYSTEM

## MEMORY CONTROLLER DESIGN

- Two Memory Controllers
- Each controller can support 1x64 for DDR4 or 2x32 using virtual channels for LPDDR4x
- 4x32 LPDDR4x-4266 (68.3 GB/s peak) OR
- 2x64 DDR4-3200 (51.2 GB/s peak)

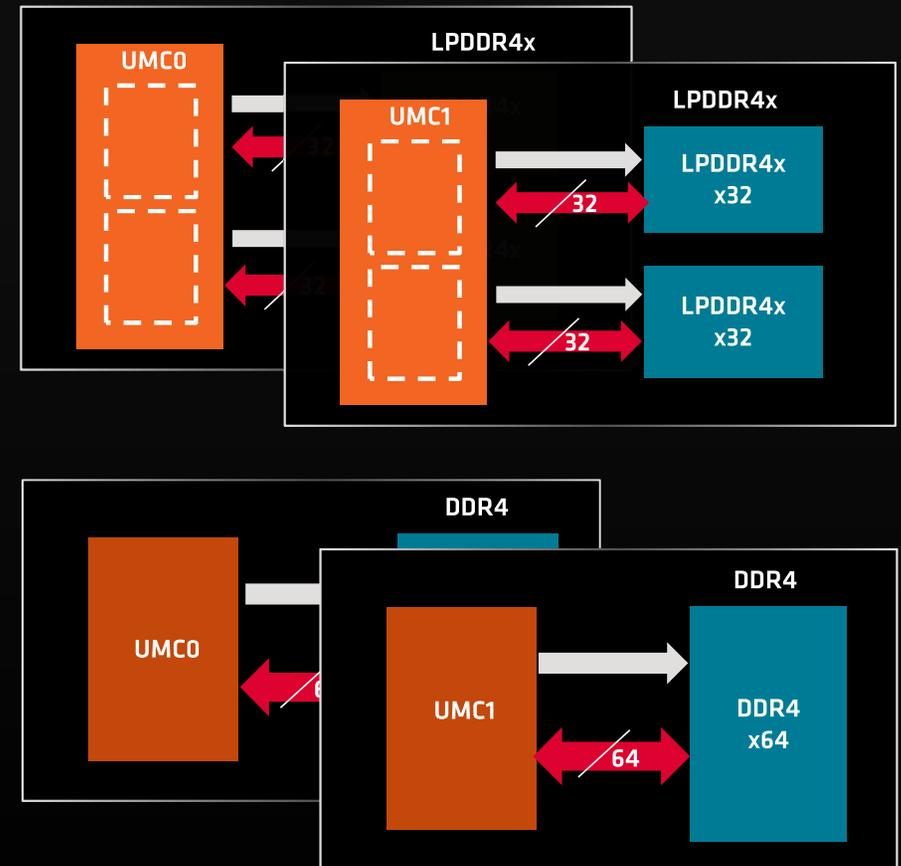

# INFINITY FABRIC

POWER OPTIMIZED FOR MOBILE

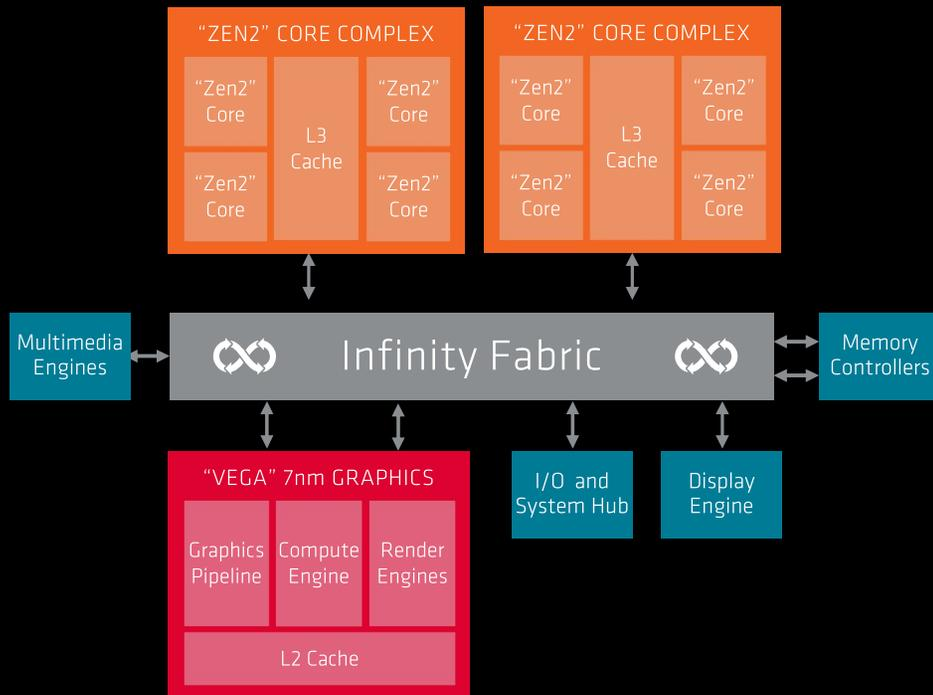

## UP TO 75% BETTER POWER EFFICIENCY

- 7nm Technology
- Optimized Fabric Performance States
- Dynamic Power optimization in the fabric switches
- Double bus width from graphics engine to fabric to improve pj/bit

## UP TO 77% HIGHER MEMORY BANDWIDTH AT LOW POWER

- DDR4-3200 and LPDDR4x-4266

SEE ENDNOTES RM3-255, RN-3

# LEADERSHIP GFX PERFORMANCE

## LOW POWER NOTEBOOKS

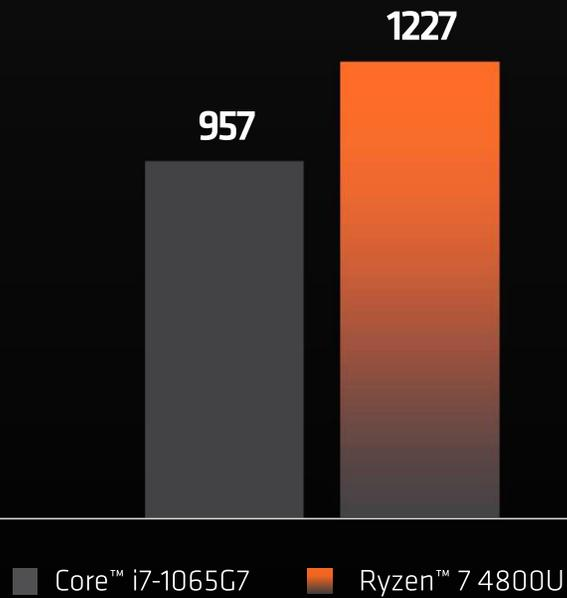

## DESKTOP WITH INTEGRATED GFX

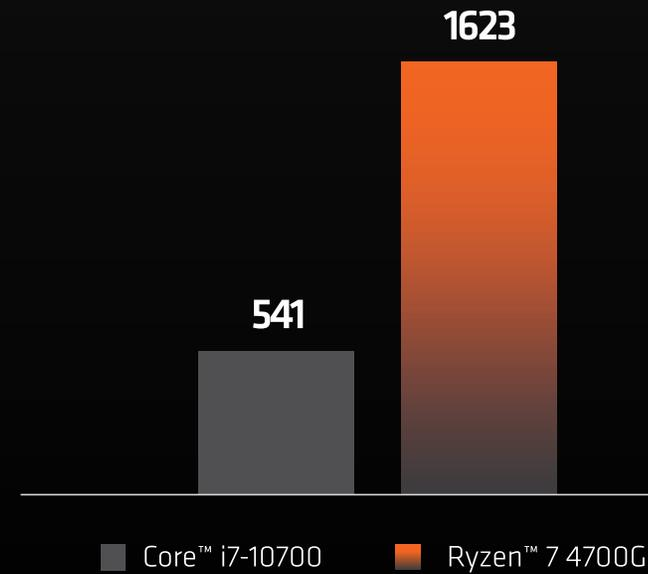

Time Spy

SEE ENDNOTES RM3-218, RZG2-69.

# INTELLIGENT LOW POWER STATE SELECTION

## “PICASSO”

- Single Power State Exposed in ACPI
- All hardware power state control done with OS input

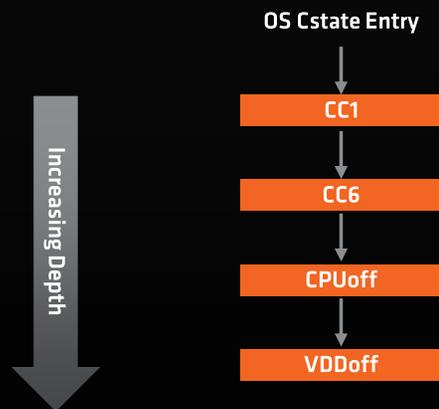

## “RENOIR”

- Three States Exposed in ACPI
- Minimum duration per state included for OS to optimally select the Cstate depth
- Reduced hysteresis between states by using OS guidance

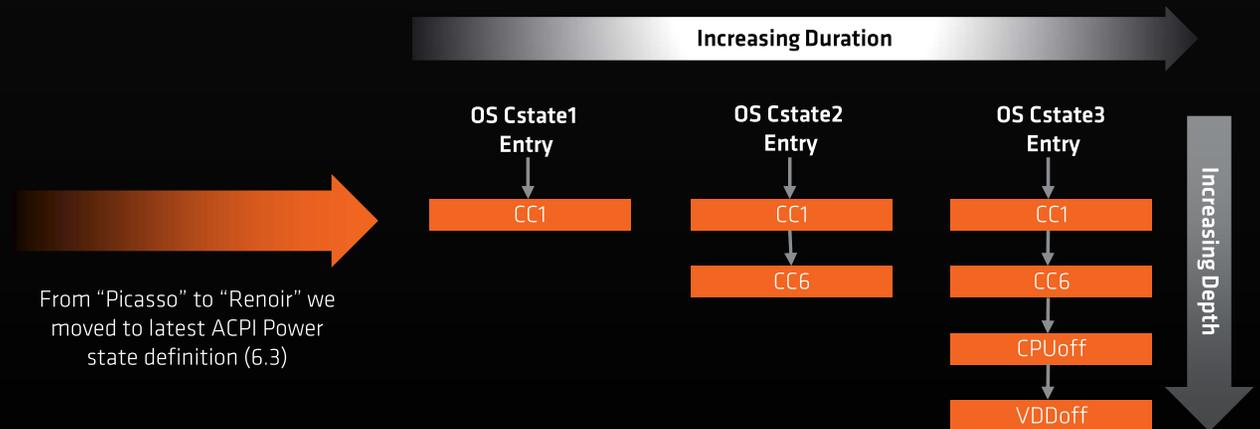

# DRIVING POWER EFFICIENCY

## IMPROVED BATTERY LIFE

### 20% REDUCED SOC POWER

- 7nm Technology enables reduced minimum voltage
- Aggressive L3 clock and power-gating
- IO Power Reduction
  - Reduced IO digital power supply
  - Reduced analog power supply for embedded display and PCIE PHYs
  - Power optimized SoC Clocking circuits

### LOW POWER STATE EFFICIENCY

- Double the save and restore bus width to reduce entry and exit latency
- Removed CPU-Off hysteresis by Intelligent Core Power State selection
- Power management firmware optimizations

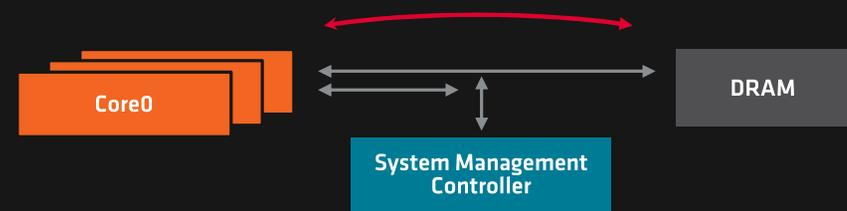

SEE ENDNOTES RM3-129, RM3-249, RM3-251.

# LOW POWER STATE RESIDENCY

## GENERATIONAL COMPARISON

### PICASSO CPU FREQUENCY

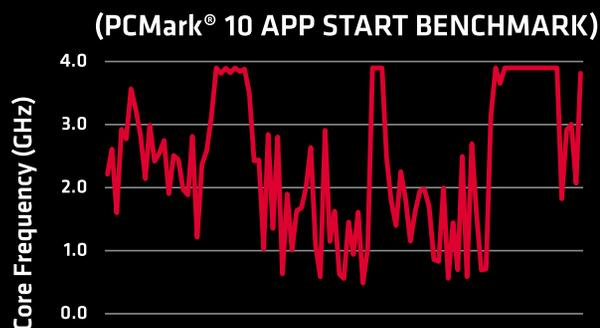

### RENOIR CPU FREQUENCY



	Picasso	Renoir
Memory Self Refresh residency	3.6 %	18.5 %
CPUOFF residency	4.5%	31.2 %
GFXOFF residency	61.7 %	71.7%
VDDOFF residency	1.7%	28.2%

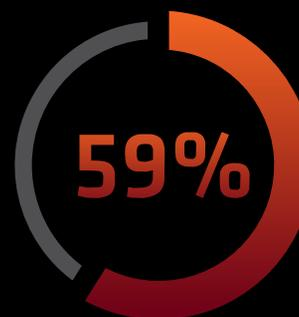

**Less Power Consumed**  
During Application Execution

SEE ENDNOTES RM3-254.

# SYSTEM TEMPERATURE TRACKING (STT) V2

FOR IMPROVED MOBILE PERFORMANCE

- Evaluates external thermal sensors in the CPU/GPU boost decision
- Diodes placed in chassis hotspots
- Thermal readings passed to Infinity Fabric via Embedded Controller (EC)
- Also works with dGPU in AMD SmartShift system configurations

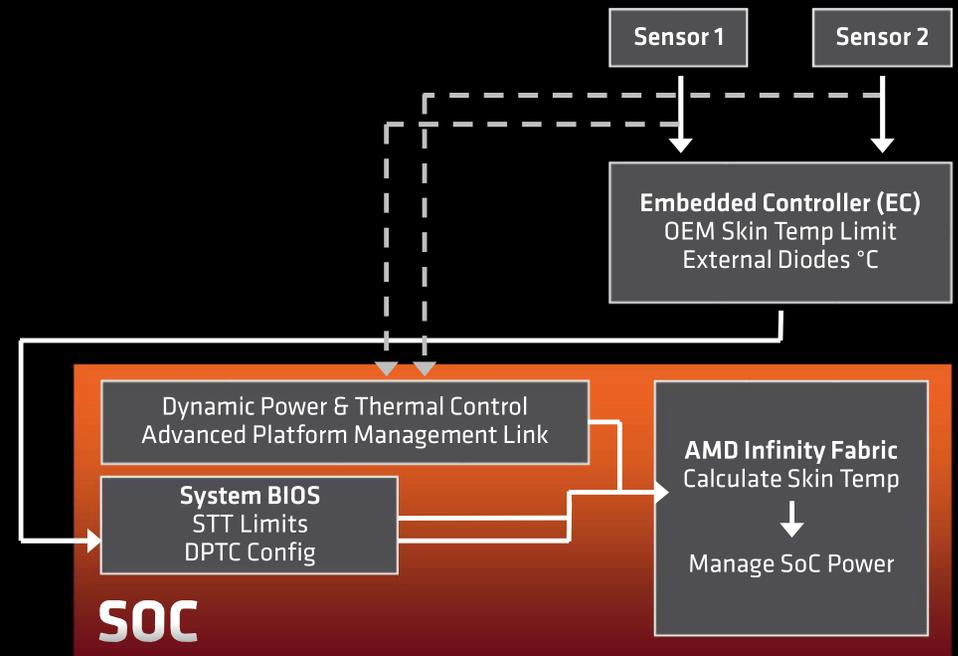

# SYSTEM TEMPERATURE TRACKING V2

## FOR IMPROVED MOBILE PERFORMANCE

- Boost durations can be extended for the user by up to 4X by considering chassis temp
- Surface temp of the notebook can be managed with a closed loop
- V2 STT simplifies OEM EC designs by pulling chassis thermal calculations into the SoC
- Works alongside AMD STAPM technology:
  - STAPM enables “high boost” by budgeting CPU power vs. a sustained limit
  - STT enables “long boost” by budgeting chassis thermals vs. a programmed limit

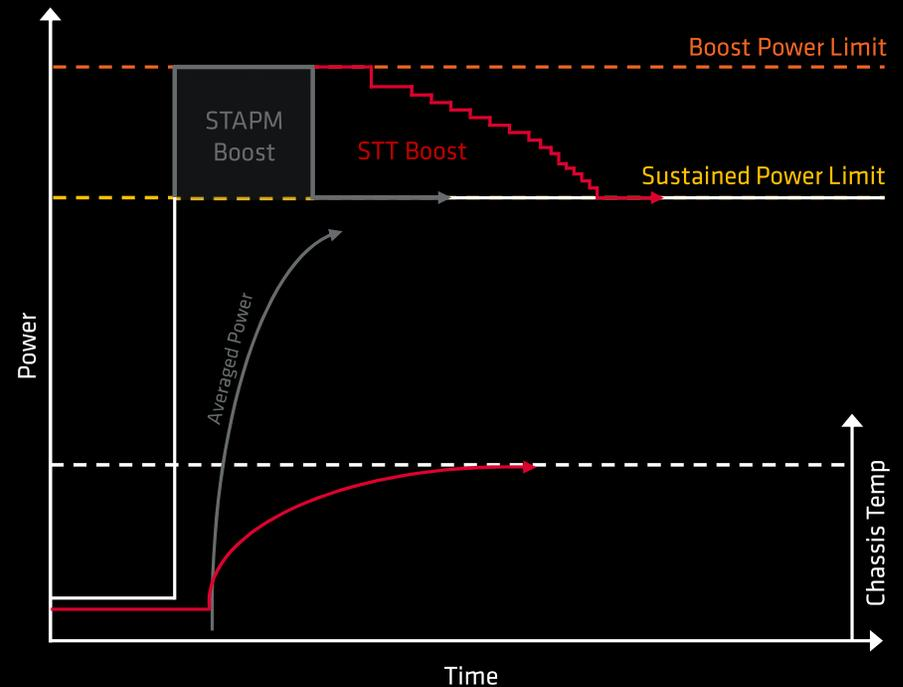

SEE ENDNOTES RM3H-17.

# ALWAYS-ON AUDIO EXPERIENCE

## "RENOIR" ACP (AUDIO CONTROLLER) SUPPORTS

### POWER EFFICIENT WAKE ON VOICE

- Designed to support popular wake words (e.g. Cortana, Alexa)
- Integrated (up to 6) PDM mic interfaces
- Full Audio Stack to enable pre-processing and spotting keyword
- Acoustic Echo Cancellation (AEC)

### LOW POWER AUDIO PLAYBACK

- Saves system power by allowing the CPU to idle for longer periods when playing audio or video on enabled Windows applications
- 20% power savings with LPAP enabled

# THE UNIVERSAL CABLE – NATIVE USB-C

HIGH BANDWIDTH DISPLAY SUPPORT + 10GB USB

USB-C with DP Alt-mode supports concurrent USB 3.2 , high bandwidth display and power charging when docked

---

Supports DisplayPort v1.4 – 8.1G HBR3 and Display Stream Compression (DSC)

“Renoir” USB-C based MST dock can support USB 3.2 and multiple monitors simultaneously\*

**Four QHD 60 Displays**

**Three QHD 144 Displays**

**Two 4K 60 + One FHD 60 (with DSC) Displays**

\*REQUIRES WINDOWS 10

# RADEON™ MULTIMEDIA ENGINE 2<sup>ND</sup> GEN

## SUPPORTS

### IMPROVED ENCODING

- New HDR/WCG encode (HEVC)
- 31% encoder speedup

### VP9

8b/10b

Youtube

#### DECODE

1080p240

4K60

### H.264

MPEG-4

8b

Twitch

#### DECODE

1080p480

4K120

#### ENCODE

1080p240

4K60

### H.265

HEVC

8b/10b

NEXT GEN

#### DECODE

1080p240

4K60

#### ENCODE

1080p240

4K60

SEE ENDNOTES GD-81, RM3-253.

# RENOIR PERFORMANCE ENHANCEMENTS FOR IMPROVED SECURITY

## AMD INTEGRATED DEVICE TRANSLATION (AIDA)

- Microsoft Hyper-V or Host translation support for integrated devices (GPU, Multimedia Accelerators, Display)
- Based on AMD IO Virtualization Technology
- Helps enable Microsoft PlayReady with reduced UMA dedicated memory frame buffer

System Memory

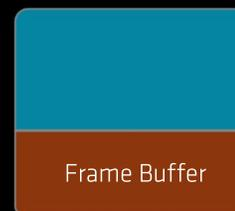

Frame Buffer

“Picasso”

System Memory



Frame Buffer

“Renoir”

Up to 75% reduction

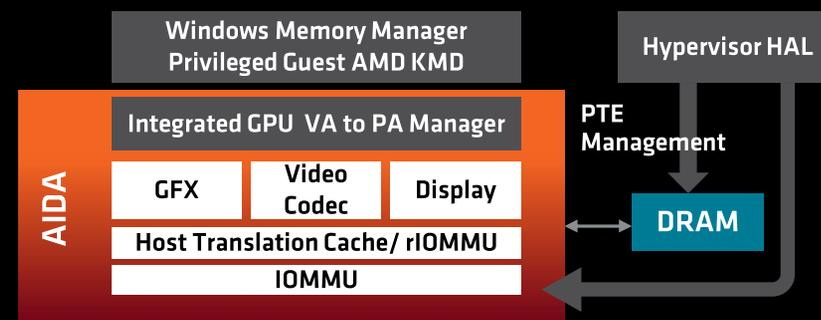

# AMD 25X20 ENERGY EFFICIENCY INITIATIVE

- In 2014, AMD set a bold goal to accelerate the energy efficiency of our mobile processors by 25x from 2014-2020
- 3<sup>rd</sup> Gen Ryzen 7 (4800H) achieved a 31.7x improvement as a result of achieving:
  - 5x more performance
  - 84% less energy use
- The gains exceed historical energy efficiency improvements by 2x

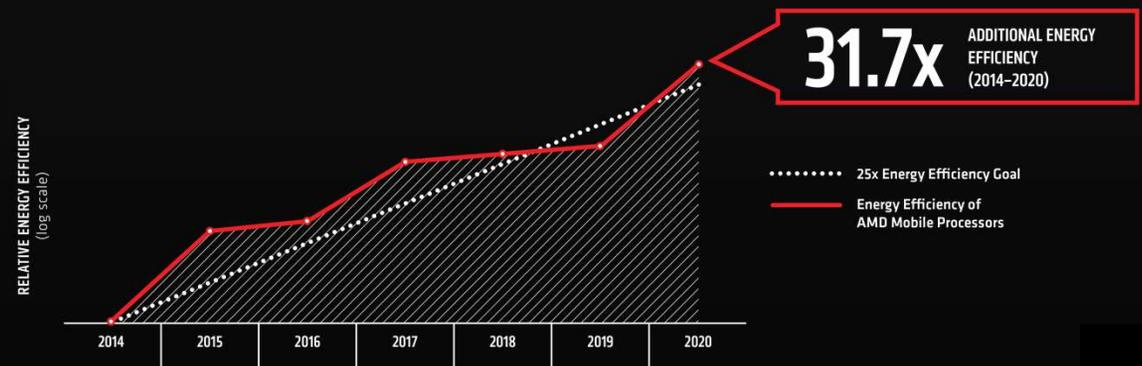

SEE ENDNOTE RVM-108

For more information and substantiation please visit [www.amd.com/25x20](http://www.amd.com/25x20)

# AMD RYZEN™ 4000 SERIES PROCESSORS

ANNOUNCED JAN 2020

First 8-core Processors  
for Ultrathin Laptops

“Zen 2” Core with 15%  
higher IPC



“Vega” 7nm Graphics  
Engine with up to 59%  
more performance per CU

Infinity Fabric and Memory  
subsystem optimized for  
energy efficiency

SEE ENDNOTES RM3-01, EPYC-09, RM3-250.

We would like to thank our talented AMD design teams across Austin, Bangalore, Boston, Fort Collins, Hyderabad, Markham, Santa Clara, and Shanghai.

---

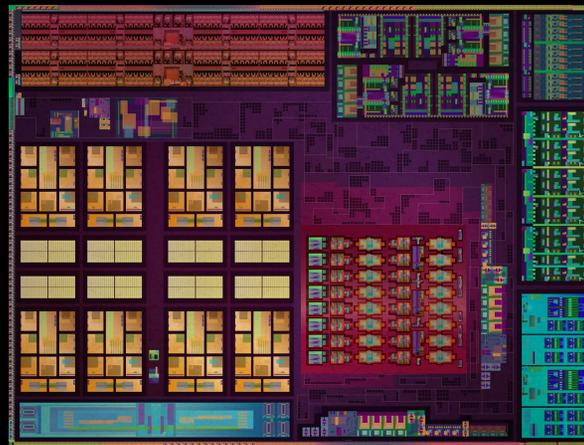

# ENDNOTES

- GD-81: HEVC (H.265), H.264, and VP9 acceleration are subject to and not operable without inclusion/installation of compatible HEVC players. GD-81
- EPYC-09: AMD “Matisse” CPU-based system scored an estimated 15% higher SPECint<sup>®</sup>\_base2006 than previous generation AMD “Summit Ridge” based systems. Estimate based on internal testing of internal “Matisse” vs. “Summit Ridge” platforms with single threaded SPEC CPU<sup>®</sup> 2006 Speed, compiled with Open64 4.2.5.1. SPEC, SPEC CPU and SPECint are registered trademarks of the Standard Performance Evaluation Corporation. For more information about SPEC, see [www.spec.org](http://www.spec.org). NOTE: When compared to Industry Trend Line on charts, the industry trend line is based on specint06 single thread run, fixed frequency (3.4 GHZ), 8M L3, open64 compiler, with performance score over the last 8 years, starting with the Intel Sandybridge in 2011.
- RM3-01: As of January 2020, the Ryzen 4000 series mobile processor is the “Most advanced laptop processor,” defined as superior 7nm process technology in a smaller node, 15W and 45W typical TDP.
- RM3-06: Testing by AMD Performance Labs as of 11/22/2019 utilizing the Ryzen 7 4800U vs. 2nd Gen Ryzen 7 3700U in Cinebench R20 Benchmark. Results may vary.
- RM3-123: Testing by AMD Performance Labs as of 11/22/2019 utilizing the Ryzen 7 4800U vs. 2nd Gen Ryzen 7 3700U in Cinebench R20 Benchmark. Results may vary.
- RM3-125: Ultrathin laptop processors defined as 15W typical TDP. As of December 20, 2019, demonstrated by Ryzen 4000 U-series mobile processor having up to 8 cores, while comparable competitive product (Intel 10th generation mobile processors) offer up to 6 cores.
- RM3-129: Testing by AMD Performance Labs as of 12/09/2019 utilizing an AMD Ryzen™ 7 4800U reference system and an AMD Ryzen™ 7 3700U reference system in Mobilemark 2014. Results may vary.
- RM3-130: Based on AMD engineering estimates, January 2020.
- RM3-249: Based on AMD performance labs internal analysis in February 2020, measuring the latency of power state entry/exit for “Renoir” processor architecture compared to previous generation “Picasso” architecture.
- RM3-250: Testing by AMD performance labs in February 2020, utilizing a Ryzen™ 7 4800 in an AMD reference system and a previous generation Ryzen™ 7 3700U in an AMD reference system and tested in 3DMark Time Spy. Results may vary. 3DMark is a registered trademark of Futuremark.
- RM3-251: Based on internal analysis by AMD performance labs in February 2020. Results may vary.
- RM3-252: Testing by AMD performance labs utilizing the Lenovo Yoga S750 configured with the Ryzen™ 4500U measuring total system power with low power audio playback (LPAP) enabled and disabled.

# ENDNOTES

- RM3-253: Based on internal analysis by AMD performance labs, February 2020.
- RM3-255: Based on internal analysis by AMD performance labs, February 2020. Results may vary.
- RM3H-17: Test data generated by AMD Performance Labs as of January 04, 2020. Testing conducted by running multiple sequential runs of 3DMark® 11 with AMD STAPM technology enabled VS. multiple sequential runs of 3DMark® 11 with AMD STT v2 technology enabled. Boost duration evaluated by comparing the performance results over time between the two boost technologies. Results may vary. RM3H-17
- RM3H-21: Testing by AMD Performance Labs as of 12/09/2019 utilizing an ASUS ROG G14 (GA401IV) laptop with AMD Ryzen™ 9 4900HS processor at 1080P with high settings in DOTA2, LOL, Rocket League, CS:GO, Far Cry 5, ME: SoW, Civ VI, Deus Ex:MD, Hitman, Total War: WH2-Battle, F1 2018, AoS, Rise of the Tomb Raider, and Strange Brigade. Results may vary.
- RM3H-22: Testing by AMD Performance Labs as of 12/09/2019 utilizing an ASUS ROG G14 (GA401IV) laptop with AMD Ryzen™ 9 4900HS processor and the MSI P75 Creator 9SF laptop with Core i9-9880H processor in Cinebench nT, HandBrake, Blender® CPU (BMW), LAME, and PCMark® 10 DCC. Results may vary. PCMark is a registered trademark of Futuremark Corporation.
- RM3H-23: Testing by AMD Performance Labs as of 12/09/2019 utilizing an ASUS ROG G14 (GA401IV) laptop with AMD Ryzen™ 9 4900HS processor and the MSI P75 Creator 9SF laptop with Core i9-9880H processor in Cinebench nT, HandBrake, Blender® CPU (BMW), LAME, and PCMark® 10 DCC. Results may vary.
- RM3-216: Testing by AMD Performance Labs as of 12/09/2019 utilizing an AMD Ryzen™ 4800U reference system and a Dell XPS 7390 system with Intel® Core i7-10710U processor in Cinebench R20 1T. Results may vary.
- RM3-217: Testing by AMD Performance Labs as of 12/09/2019 utilizing an AMD Ryzen™ 4800U reference system and a Dell XPS 7390 system with Intel® Core i7-10710U processor in Cinebench R20 nT. Results may vary.
- RM3-218: Testing by AMD Performance Labs as of 12/09/2019 utilizing an AMD Ryzen™ 4800U reference system and a Dell XPS 7390 system with Intel® Core i7-10710U processor in 3DMark® Time Spy. Results may vary. 3DMark is a registered trademark of Futuremark Corporation.
- RM3-254: Testing by AMD performance labs measuring the average APU power consumption of the Ryzen 4800U compared to the Ryzen 7 3700U PRO while running PCMark® 10 Applications test.

# ENDNOTES

- RVM-108: Testing by AMD Performance Labs as of 4/15/2020. Processors tested: AMD FX-7600P, AMD FX-8800P, AMD FX-9830P, AMD Ryzen 7 2700U, AMD Ryzen 7 2800H, AMD Ryzen 7 3750H, and AMD Ryzen 7 4800H. 25x20 program tracked against Energy Star Rev 6.1 8/12/2014 and 3DMark® 2011 P-Score and Cinebench R15 nT. Results may vary with drivers and BIOSes. The normalized performance increase is 5x higher from AMD's 2014 notebook processor to the 2020 design. This equates to one-fifth the average compute time for a given task. Annual processor electricity use (kwh), based on ENERGY STAR typical use energy consumption (TEC), in 2020 equals 84% less than the 2014 amount. AMD achieved a 31.7x increase in typical use energy efficiency from 2014-2020, or ~2x compared to what would be the historical rate of increase (doubling every 1.57 years) during the same timeframe of 14.1x.
- RN-1: Based on AMD Internal evaluation comparing die size and transistor count of Renoir SoC Die in 7nm to Raven-Picasso SoC Die in GF14/12
- RN-2: Based on AMD internal analysis. Compared Vega 14nm (11 CU, Picasso) area to Vega 7nm (8 CU, Renoir) area. Performance density is evaluated by calculating a ratio of Performance per unit area.
- RN-3: Based on AMD internal analysis Feb 2020. Compared max speed for Picasso mobile notebook to Renoir mobile
- RZG2-68: Based on testing by AMD Labs on 6.9.2020 using Cinebench R20 1T and nT benchmarks. Performance may vary.
- RZG2-69: Based on testing by AMD Labs in June 2020, using the 3DMark Timespy benchmark. Results may vary. 3DMark is a registered trademark of Futuremark Corporation.

**AMD** 